



Features

- True RMS-To-DC Conversion
- Computes RMS of AC and DC Signals
- 600mVrms full scale ($\pm 3V$ supply)
- Wide Response :
 - ◇ 1MHz 3dB Bandwidth for $V_{RMS} > 100mV_{RMS}$
- Single or Dual Supply Operation
- dB output (60 dB dynamic range)
 $V_{in}=2mV\sim 2V @ V_s=\pm 5V$
- Power Down Function:
Quiescent current reduction from 1.0mA to 5uA
- Buffered Voltage Output
- 14-lead SOIC (150mil width)

Description

The ES5A is a true RMS-to-DC dB converter. It accepts low-level input signals from 0 to 600 mV_{RMS} complex input waveforms. It can be operated form either a single supply or dual supplies. The device draws less than 1.2 mA of quiescent supply current, furthermore, a chip select pin is provided to power-down mode of the device, making it ideal for battery-powered applications.

Application

- * Battery-Powered Instruments
- * dB level Meter

Pin Assignment

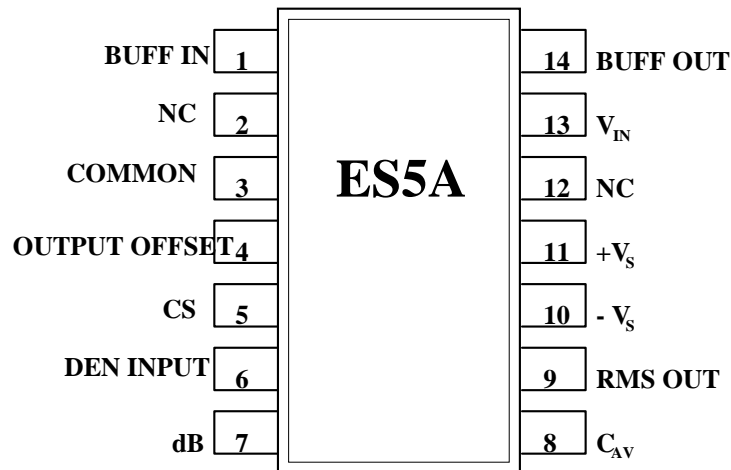

NC = NO CONNECT
SOP 14Pin Package



Electrical Characteristics

(TA = +25°C, VS = +3V, -VS = -3V, unless otherwise noted.)

| PARAMETER | CONDITIONS | MIN | TYP | MAX | UNITS |
|--|---|---|-----------------|---------------|-----------------------|
| Transfer Equation | | $V_{OUT} = [\text{avg.}(V_{IN})^2]^{1/2}$ | | | |
| Averaging Time Constant | | 25 | | | ms/μF C _{AV} |
| CONVERSION ACCURACY | | | | | |
| Total Error, Internal Trim (Notes 1,2) | | | | ±1.0 ±2.0 | mV ±% of Reading |
| Total Error vs. Temperature | -40°C to +85°C | | | ±0.1 ±0.01 | mV ±% of Reading/°C |
| Total Error vs. Supply | +VIN=300mV -VIN=-300mV | | 30 100 | 150 300 | μV ±% of |
| DC Reversal Error | Vin= 600mV | | ±0.3 | | ±% of Reading |
| Total Error, External Trim | (Note 1) | | | ±0.25 ±0.1 | mV ±% of Reading |
| ERROR vs. CREST FACTOR | | | | | |
| Additional Error (Note 3) | Crest Factor 1 to 2 Crest Factor = 3 Crest Factor = 6 | Specified Accuracy ±0.1 ±0.5 | | | ±% of Reading |
| FREQUENCY RESPONSE (Note 2,4) | | | | | |
| Bandwidth for 1% Additional Error (0.09dB) | VIN =10mV VIN =100mV VIN =600mV | | 11 90 200 | | KHz KHz KHz |
| ±3dB Bandwidth | VIN =10mV VIN =100mV VIN =600mV | | 130 1 3 | | KHz MHz MHz |
| INPUT CHARACTERISTICS | | | | | |
| Input Signal range | Continuous RMS, All Supplies | 0 to 600 | | | mVRMS |
| | Peak Transient | ±3.0V Supplies ±5V Supplies | | 2.2 5.0 | V _{PK} |
| Input Resistance | | | 6 | | KΩ |
| Input Offset Voltage | | | | ±0.5 | mV |
| OUTPUT CHARACTERISTICS (Note 1) | | | | | |
| Offset Voltage (Vin=COM) | TA=+25°C | | | ±0.5 | mV |
| | TA=-40~85 °C | | | ±0.1 | mV/°C |
| Output Voltage Swing | +3V, -3V Supplies | | 2.2 | | V |
| Output Current | | 5 | | | mA |
| Short-Circuit Current | | | 18 | | mA |
| Output Resistance | Chip Select High | | 0.5 | | Ω |
| | Chip Select Low | | 100 | | KΩ |
| dB OUTPUT (Vs = ±5V) | | | | | |
| ERROR | 2mVrms ≤ VIN ≤ 2Vrms | | ±0.6 | ±1.0 | dB |
| Scale Factor | | | -3 | | mV/dB |
| Scale Factor temp.coefficient | TA =-40~85 °C | | +0.35% | | Readings/°C |
| I _{REF} | 0dB=1VRMS | 5 | 20 | 80 | μA |
| I _{REF} Range | | 1 | | 100 | μA |
| DENOMINATOR INPUT | | | | | |
| Input Range | | 0 to 2 | | | V |
| Input Resistance | | | 25 | | kΩ |
| Offset Voltage | | | ±0.2 | | V |
| BUFFER AMPLIFIER | | | | | |
| In/Out Voltage Range | | -Vs to (+Vs-1.8V) | | | V |
| Input Offset Voltage | | | ±0.8 | ±1.5 | mV |
| Input Resistance | | | 10 ⁸ | | Ω |
| Output Current | | | | 5 | mA |
| Short-Circuit Current | | | 20 | | mA |
| Small-Signal Bandwidth | | | 1 | | MHz |
| Slew Rate (Note 5) | | | 5 | | V/μs |



Electrical Characteristics (continued)

(TA = +25°C, Vs = +3V, -Vs = -3V, unless otherwise noted.)

| PARAMETER | CONDITIONS | MIN | TYP | MAX | UNITS |
|----------------------------|---|------|-----|-----|-------|
| Power SUPPLY | | | | | |
| Dual Supplies | | ±2.5 | | ±6 | V |
| Standby Current | Connect CS to -Vs and Pin4 is connected to COMMON (Figure.1). | | | 2 | μA |
| Quiescent Current (Note 6) | | | 1 | | mA |

Note 1: Accuracy is specified for 0 to 600mV, 1kHz sine-wave input. Accuracy is degraded at higher RMS signal levels.

Note 2: Measured at pin9 (RMS OUT), with pin 4 tied to COMMON.

Note 3: Error vs. crest factor is specified as an additional error for 300mVRMS rectangular pulse input, pulse width = 200 μs.

Note 4: Input voltages are expressed in volts V_{RMS}

Note 5: With 10 kΩ external pull-down resistor from pin 14 (BUFF OUT) to -Vs.

Note 6: With BUF input tied to COMMON.



Standard Connection

The ES5A is simple to connect for a majority of rms measurements. In the standard rms connection shown in Figure 1, only an external capacitor is required to set the averaging time constant. In this configuration, the ES5A computes the True RMS value of any input signal. The magnitude of an averaging error is dependent on the value of the averaging capacitor, is existed at lower frequencies. For example, if the filter capacitor, C_{AV} , is $4.7\mu F$, the error is 0.3% at 10Hz. To measure ac signal, the ES5A can be ac-couples by adding a capacitor in series with the input, as shown in Figure 1.

The performance of the ES5A is tolerant of minor variations in the power supply voltages; however, if the supplies used exhibit a considerable amount of high frequency ripple, it is advisable to bypass both supplies to ground through a $0.1\mu F$ ceramic disc capacitor places as close to the device as possible.

The output signal range of the ES5A is a function of the supply voltages, the output signal can be used buffered or nonbuffered, depending on the characteristics of the load. If no buffer is needed, tie the buffer input (Pin 1) to common. The output of the ES5A is capable of driving 5mA into a $2K\Omega$ load without degrading the accuracy of the device.

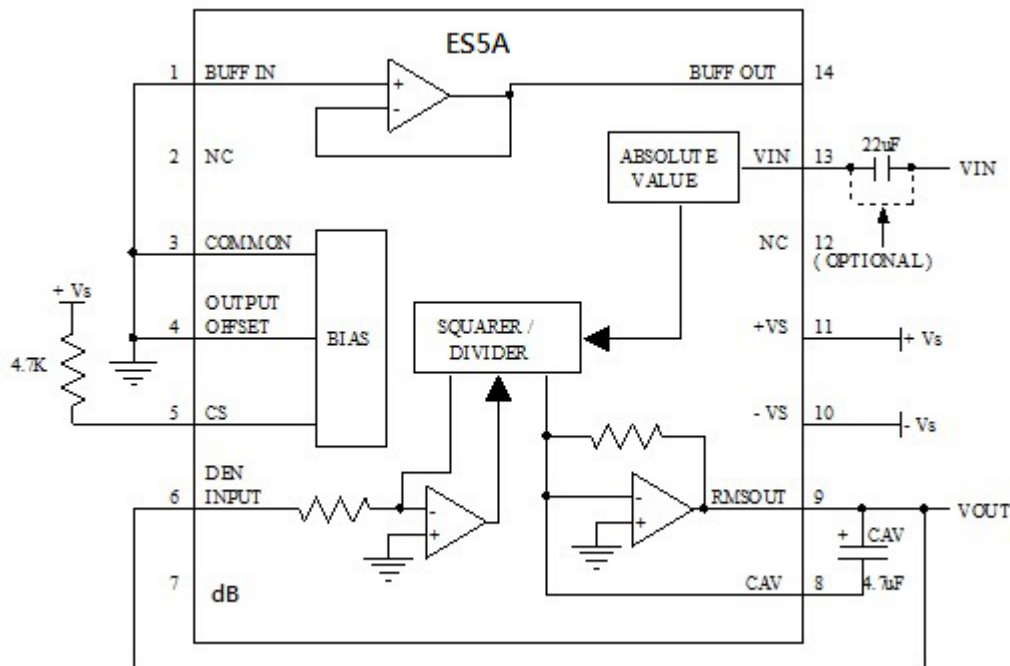

Figure 1. Standard connection for ES5A



High-Accuracy Adjustments

The accuracy of the ES5A can be further improved by the external trimming scheme as shown in Figure 2. The input should be grounded and R1 adjusted to give 0V output offset from pin 9. Alternatively, R1 could be adjusted to give the correct output with the lowest expected value of VIN. The R4 is in series with the pin13 to lower the range of the scale factor. Connect the desired full scale to VIN by using a DC or AC signal (ex. 500mV_{RMS}), and R3 is trimmed to give the correct value for a calibrated signal.

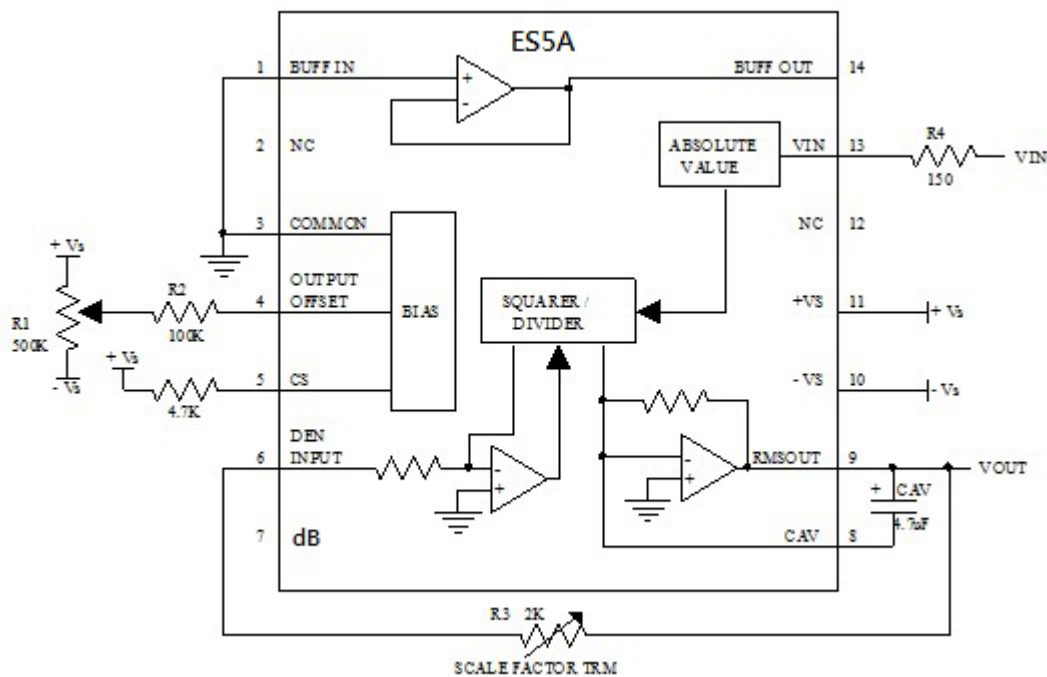

Figure 2. Optional External Gain and Offset Trims

Chip Select

The ES5A provides a chip select pin (Pin 5). To enable the device, this pin must be connected to +Vs. If it is connected to -Vs or floated, the device will enter power-down mode. The current it draws at this mode is less than 10uA. (Figure 1.)

Choosing the Averaging Time Constant

The ES5A computes the RMS value of AC and DC signals. At low frequencies and DC, the output tracks the input exactly; at higher frequencies, the average output approaches the RMS value of the input signal. The actual output differs from the ideal by an average (or DC) error plus some amount of ripple.

The DC error term is a function of the value of C_{AV} and the input signal frequency. The output ripple is inversely proportional to the value of C_{AV} . Waveforms with high crest factors, such as a pulse train with low duty cycle, should have an average time constant chosen to be at least ten times the signal period.

Using a large value of C_{AV} to remove the output ripple increases the setting time for a step change in the input signal level.

The primary disadvantage in using a large C_{AV} to remove ripple is that the settling time for a step change in input level is increased proportionately. A better method to reduce the settling time and ripple is to use a post filter. A suggested circuit is shown in Figure 3. The 1-pole or 2-pole filter configuration allows a smaller C_{AV} . With post filter, the value of C_{AV} should be just large enough to give the maximum dc error at the lowest frequency of interest. And the output ripple will be removed by the post filter.

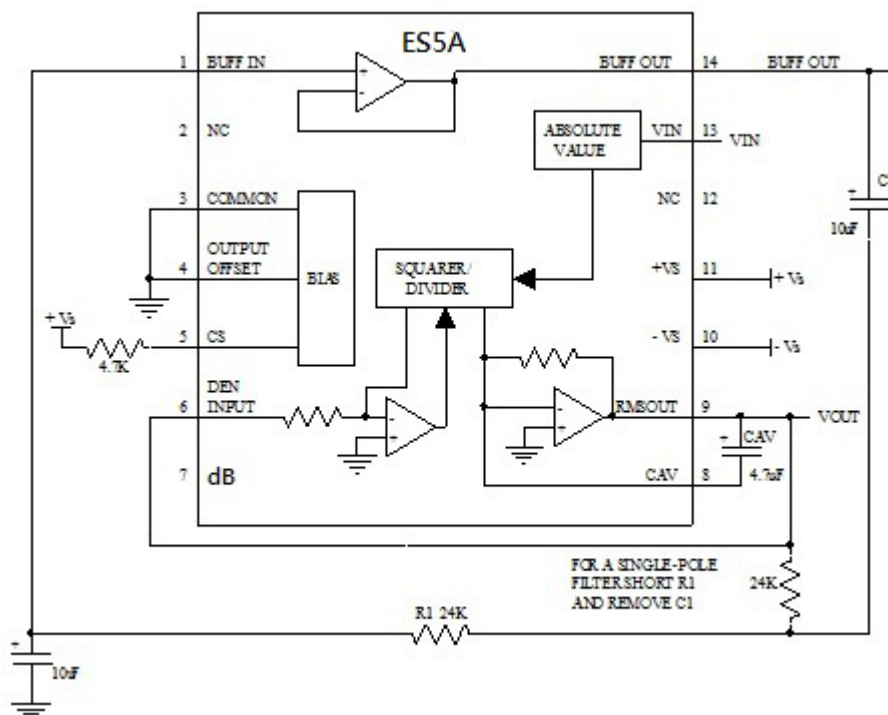

Figure 3. 2-Pole Filter



dB meter application

Another feature for the ES5A is logarithmic or decibel output. The internal circuits of ES5A calculate the dB output and works for 60dB range. Figure 4 shows the dB meter connection. Select the 0dB level by setting R1 for proper 0dB reference current. The external OPAMP circuit is used to provide a scale and to allow compensation of the temperature drift of dB circuit.

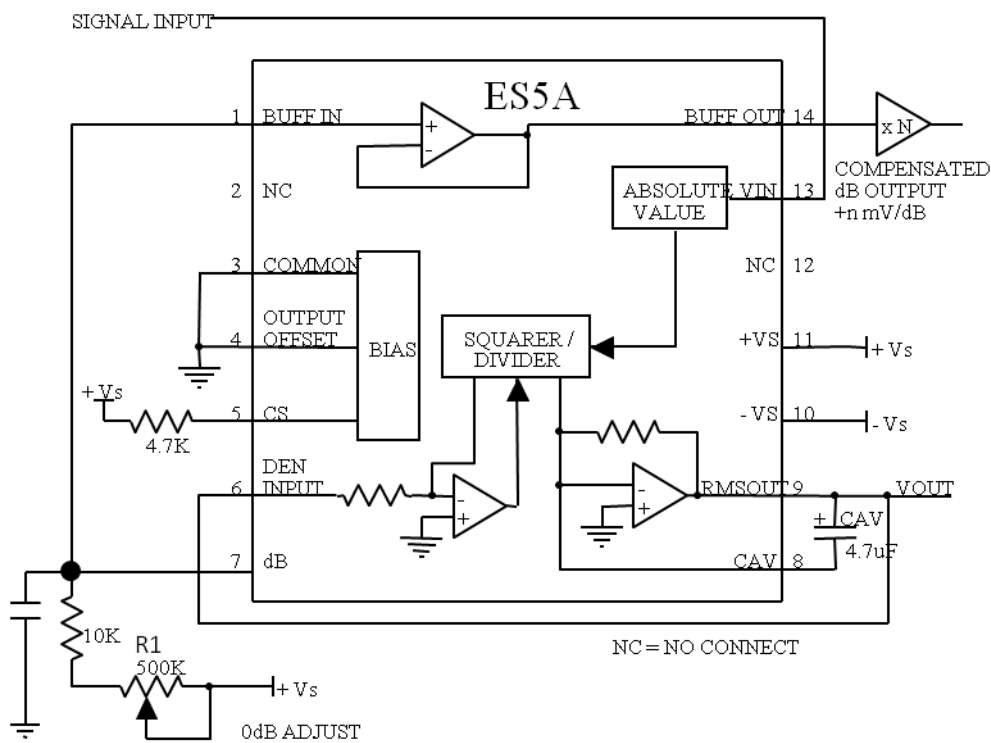
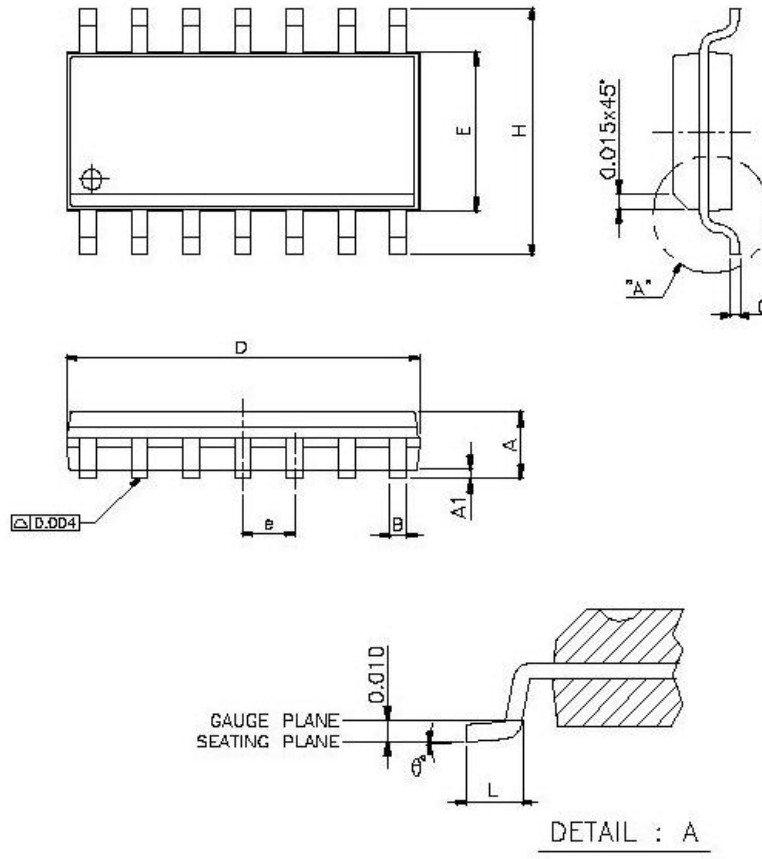

Figure 4. dB connection



Packaging

14 Pin SOP Package



2. Dimension Parameters

| SYMBOLS | MIN. | NOM. | MAX. |
|---------|--------|-------|--------|
| A | 0.058 | 0.064 | 0.068 |
| A1 | 0.004 | — | 0.010 |
| B | 0.013 | 0.016 | 0.020 |
| C | 0.0075 | 0.008 | 0.0098 |
| D | 0.336 | 0.341 | 0.344 |
| E | 0.150 | 0.154 | 0.157 |
| e | — | 0.050 | — |
| H | 0.228 | 0.236 | 0.244 |
| L | 0.015 | 0.025 | 0.050 |
| θ° | 0° | — | 8° |

UNIT : INCH

NOTES:

1. JEDEC OUTLINE : MS-012 AB
2. DIMENSIONS "D" DOES NOT INCLUDE MOLD FLASH, PROTRUSIONS OR GATE BURRS. MOLD FLASH, PROTRUSIONS AND GATE BURRS SHALL NOT EXCEED .15mm (.006in) PER SIDE.
3. DIMENSIONS "e" DOES NOT INCLUDE INTER-LEAD FLASH, OR PROTRUSIONS. INTER-LEAD FLASH AND PROTRUSIONS SHALL NOT EXCEED .25mm (.010in) PER SIDE.