

Features

- 6000 counts dual-slope SADC (2-5 cnvs/s.)
- Input signal full scale: 630mV (Max. 6300 count)
- Built-in 600 counts fast speed (x10) FADC
- Fast ADC conversion rate: 20-50 times/s
- 100L LQFP package
- 3V DC regulated power supply
- Support digital multi-meter function
 - *Voltage measurement (AC/DC)
 - *Current measurement (AC/DC)
 - *Support AC+DC RMS mode
 - *Dual mode for frequency with voltage or current
 - *Resistance measurement (600.0Ω – 60.00MΩ)
 - *Capacitance measurement (6.000nF – 60.00mF)
(Taiwan patent no.: 323347, 453443)
(China patent no.: 200710106702.8)
 - *Diode or continuity mode measurement
 - *Frequency counter with duty cycle display:
60.00Hz – 60.00MHz
5% – 95%
- ADP mode (AC or DC mode is available)
- 3dB BW selectable for low pass filter at AC mode
(Taiwan patent no.: 362409)
(China patent no.: 200920156001.X)
- Band-gap reference voltage output
- Peak-hold measurement
(Taiwan patent no.:476418)
- 3-wire serial bus for MPU I/O port
- MPU I/O power level selectable by external pins
- On-chip buzzer driver and frequency selectable by MPU command
- High-crest-factor signal detection
(Taiwan patent no.: 234661)
- Multi-level battery voltage detection
- Support sleep mode by external chip select pin

Application

Clamp-on meter

Digital multi-meter

Description

ES51996 is an analog frond end chip of DMM built-in 6000(SADC)/600(FADC) counts dual ADCs. The SADC is operated at slower speed for higher resolution. The FADC is operated at higher speed for lower resolution. ES51996 provides voltage & current (AC/DC) measurement, resistance measurement, capacitance measurement, diode/continuity measurement, frequency measurement, duty cycle measurement and voltage peak-hold function. An analog switches network is built-in for insulation resistance application. The ES51996 also supports multi-level battery detection, low-pass-filter feature for AC mode and dual mode measurement for V+F & A+F. A 3-wire serial bus for MPU I/O port will be used easily for firmware design. Flexible function design is supported for different kinds of DMM or Clamp-on meter application.



Pin Assignment

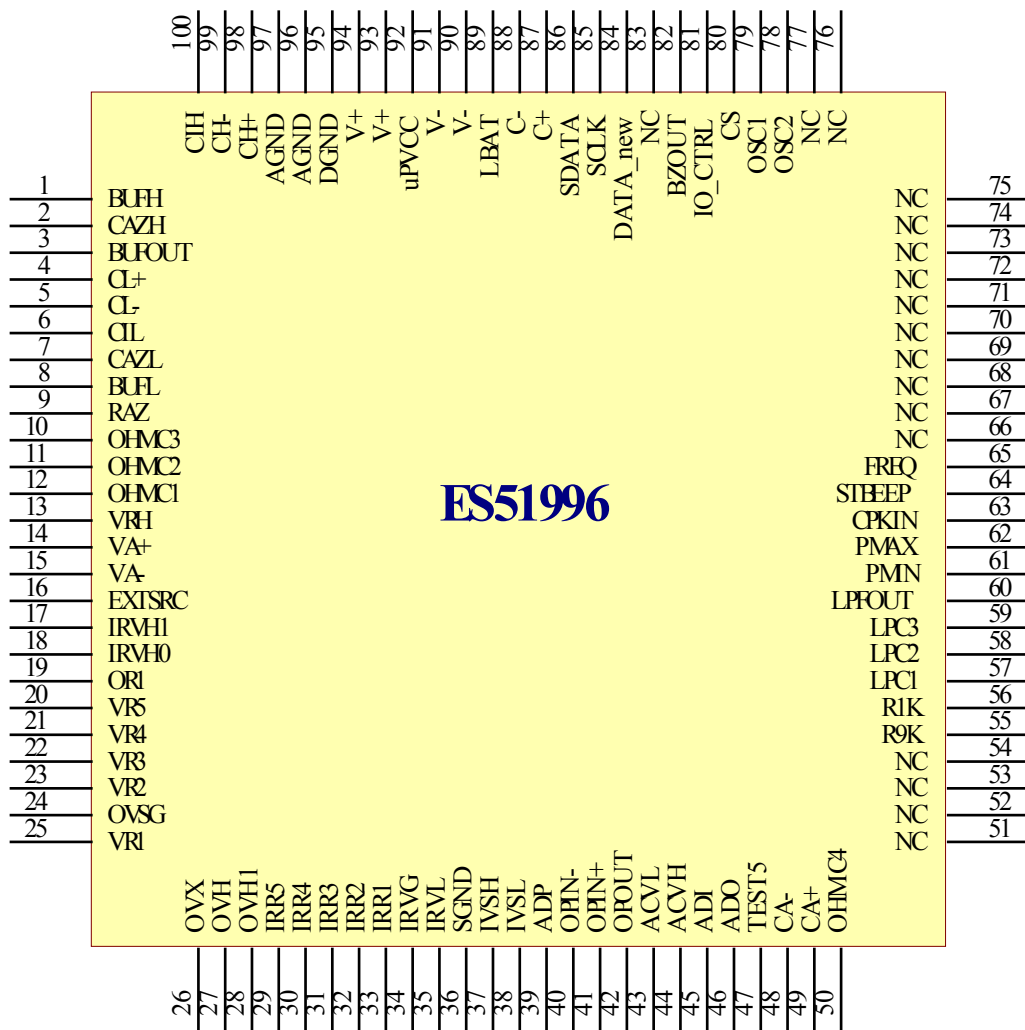



Pin Description

Pin No	Symbol	Type	Description
1	BUFH	O	High-speed buffer output pin. Connect to integral resistor.
2	CAZH	O	High-speed auto-zero capacitor connection.
3	BUFOUT	O	Filter capacitor connection for AC+DC RMS mode.
4	CL+	IO	Positive connection for reference capacitor of high-resolution A/D.
5	CL-	IO	Negative connection for reference capacitor of high-resolution A/D.
6	CIL	O	High-resolution integrator output. Connect to integral capacitor.
7	CAZL	O	High-resolution auto-zero capacitor connection.
8	BUFL	O	High-resolution Buffer output pin. Connect to integral resistor
9	RAZ	O	Buffer output pin in AZ and ZI phase.
10	OHMC3	O	Filter capacitor connection for resistance mode.
11	OHMC2	O	Filter capacitor connection for resistance mode.
12	OHMC1	O	Filter capacitor connection for resistance mode.
13	VRH	O	Output of band-gap voltage reference. Typically -1.23V
14	VA+	I	De-integrating voltage positive input. The input should be higher than VA-.
15	VA-	I	De-integrating voltage negative input. The input should be lower than VA+.
16	EXTSRC	I	External source input available for Res/Diode/ADP mode
17	IRVH1	O	High voltage measurement range1 for insulation R mode
18	IRVH0	O	High voltage measurement range0 for insulation R mode
19	OR1	O	Reference resistor connection for 600.0Ω range
20	VR5	O	Voltage measurement ÷10000 attenuator(1000V)
21	VR4	O	Voltage measurement ÷1000 attenuator(600.0V)
22	VR3	O	Voltage measurement ÷100 attenuator(60.00V)
23	VR2	O	Voltage measurement ÷10 attenuator(6.000V)
24	OVSG	O	Sense low voltage for resistance/voltage measurement
25	VR1	I	Measurement Input. Connect to a precise 10MΩ resistor.
26	OVX	I	Sense input for resistance/capacitance measurement
27	OVH	O	Output connection for resistance measurement
28	OVH1	O	Output connection1 for resistance measurement (optional)
29	IRR5	I	Test mode used (optional)
30	IRR4	I	Current shunt resistor4 connection for insulation R mode
31	IRR3	I	Current shunt resistor3 connection for insulation R mode
32	IRR2	I	Current shunt resistor2 connection for insulation R mode
33	IRR1	I	Current shunt resistor1 connection for insulation R mode
34	IRVG	I	Voltage measurement terminal low-side of shunt resistor
35	IRVL	I	Voltage measurement terminal high-side of shunt resistor
36	SGND	G	Signal Ground.
37	IVSH	I	Current measurement input for 6000μA, 600mA and 60A modes.
38	IVSL	I	Current measurement input for 600μA, 60mA.
39	ADP	I	Measurement input in ADP mode.
40	OPIN-	I	Independent operational amplifier negative input
41	OPIN+	I	Independent operational amplifier positive input
42	OPOUT	O	Independent operational amplifier output
43	ACVL	O	DC signal low input in ACV/ACA mode. Connect to negative output of external AC to DC converter.
44	ACVH	O	DC signal high input in ACV/ACA mode. Connect to positive output of external AC to DC converter.
45	ADI	I	Negative input of internal AC-to-DC OPAMP.
46	ADO	O	Output of internal AC-to-DC OPAMP.
47	TEST5	O	Buffer output of OVSG
48	CA-	IO	Negative auto-zero capacitor connection for capacitor measurement
49	CA+	IO	Positive auto-zero capacitor connection for capacitor measurement



50	OHMC4	O	Filter capacitor connection for resistance mode.
51	NC	-	Not connected
52	NC	-	Not connected
53	NC	-	Not connected
54	NC	-	Not connected
55	R9K	O	Connect to a precise 9KΩ resistor for capacitor measurement.
56	R1K	O	Connect to a precise 1KΩ resistor for capacitor measurement.
57	LPC1	O	Capacitor C1 connection for internal low-pass filter
58	LPC2	O	Capacitor C2 connection for internal low-pass filter
59	LPC3	O	Capacitor C3 connection for internal low-pass filter
60	LPFOUT	O	Capacitor C1 connection for internal low-pass filter
61	PMIN	O	Minimum peak hold output
62	PMAX	O	Maximum peak hold output.
63	CPKIN	I	Bypass capacitor for peak mode
64	STBEEP	O	Fast low-impedance sensed output for CONT./Diode mode Build-in a internal comparator for OVX pin.
65	FREQ	I	Frequency counter input, offset V-/2 internally by the chip.
66-77	NC	-	Not connected
78	OSC2	O	Crystal oscillator output connection
79	OSC1	I	Crystal oscillator input connection
80	CS	I	Set to high to enable ES51996. Set to low to enter sleep mode
81	IO_CTRL	I	MPU I/O level LOW setting. Connect to DGND or V-.
82	BZOUT	I	Buzzer frequency output. Normal low state.
83	NC	-	Not connected
84	DATA_NEW	O	New ADC data ready
85	SCLK	I	Serial clock input
86	SDATA	IO	Serial data input/output
87	C+	O	Positive capacitor connection for on-chip DC-DC converter.
88	C-	O	Negative capacitor connection for on-chip DC-DC converter.
89	LBAT	I	Low battery configuration input.
90	V-	P	Negative supply voltage.
91	V-	P	Negative supply voltage.
92	uPVCC	P	MCU I/O power level connection.
93	V+	O	Output of on-chip DC-DC converter.
94	V+	O	Output of on-chip DC-DC converter.
95	DGND	G	Digital ground.
96	AGND	G	Analog ground.
97	AGND	G	Analog ground.
98	CH+	IO	Positive connection for reference capacitor of high-speed A/D.
99	CH-	IO	Negative connection for reference capacitor of high-speed A/D.
100	CIH	O	High-speed integrator output. Connect to integral capacitor.



Absolute Maximum Ratings

Characteristic	Rating
Supply Voltage (V- to AGND)	-4V
Analog Input Voltage & EXT SRC pin	V- -0.6 to V+ +0.6
V+	V+ \geq (AGND/DGND+0.5V)
AGND/DGND	AGND/DGND \geq (V- -0.5V)
Digital Input (IO_CTRL=V-)	V- -0.6 to uPVCC+0.6
Power Dissipation. Flat Package	500mW
Operating Temperature	-20°C to 70°C
Storage Temperature	-55°C to 125°C

Electrical Characteristics

TA=25°C, V- = -3.0V

Parameter	Symbol	Test Condition	Min.	Typ.	Max	Units
Power supply	V-		-2.8	-3.0	-3.2	V
Operating supply current	I _{DD}	Normal operation	—	2.8	3.2	mA
In DCV mode	I _{SS}	In sleep mode	—	1	3	μA
SADC ² Voltage roll-over error		10MΩ input resistor	—	—	±0.1	%F.S ¹
FADC ³ Voltage roll-over error		10MΩ input resistor	—	—	±0.5	%F.S ¹
SADC ² voltage nonlinearity	NLV1	Best case straight line	—	—	±0.1	%F.S ¹
FADC ³ voltage nonlinearity	NLV2	Best case straight line	—	—	±1.0	%F.S ¹
Voltage full scale range of SADC ²		VA+-VA- = 200mV	—	600	630	mV
Voltage full scale range of FADC ³		VA+-VA- = 200mV	—	600	—	mV
Input Leakage for VR1 input			-10	1	10	pA
Zero input reading		10MΩ input resistor	-000	000	+000	Count
Band-gap reference voltage	V _{RH}	100KΩ resistor between VRH and AGND	-1.30	-1.22	-1.14	V
Open circuit voltage for 600Ω range measurement			—	V-	—	V
Open circuit voltage for other Ω measurement			—	V _{RH}	—	V
Internal pull-high to 0V current		Between V- pin and CS	—	1.2	—	μA
AC frequency response at 6.000V range		±1%	—	40-400	—	HZ
		±5%	—	400-2000	—	
OP unity gain bandwidth	GB	C _L =10pF	—	200	—	kHz
OP slew rate at unity gain	SR	R _L =10MΩ	—	3.5	—	V/us
OP input offset voltage	V _{IO}		—	0.1	—	mV
OP input bias current	I _B		—	10	—	pA
OP input common mode voltage range	V _{ICR}		—	±2	—	V
3dB frequency for LPF ⁴ active	f _{3dB}	3dB=Full (ADP)	100	—	—	kHz
		3dB=10k (ADP)	—	10	—	kHz
		3dB=1k (ADP)	—	1	—	kHz



Multi-level low battery detector	V_{t1}	LBAT vs. V-	—	2.15	—	V
	V_{t2}		—	2.03	—	V
	V_{t3}		—	1.83	—	V
Peak-hold mode pulse width		ACIN =40 ~ 400Hz	100 ⁶	1000	—	us
STBEEP comparator in Diode mode		OVX to SGND	—	+9	—	mV
STBEEP comparator in Cont. mode		OVX to SGND	—	-7	—	mV
HCF detection voltage		VR2-VR5	—	1100	—	mV
Frequency input sensitivity (<i>FREQ</i>)	Fin	Square wave with Duty cycle 40-60%	500	—	—	mVp
Frequency input sensitivity (<i>FREQ</i>)	Fin	Sine wave	400	—	—	mVrms
Reference voltage temperature coefficient	TC_{RF}	100K Ω resistor Between VRH -20 $^{\circ}$ C < TA < 70 $^{\circ}$ C	—	—	50	ppm/ $^{\circ}$ C
Capacitance measurement Accuracy ⁵		6.0nF – 60mF	-2.5	—	2.5	%F.S
			-3	—	3	counts

Note:

1. Full Scale (6000 counts for SADC and 600 counts for FADC)
2. SADC = High resolution ADC (slow speed)
3. FADC = High speed ADC (lower resolution)
4. ES51996 built-in 3rd order low pass filter available for AC mode
5. Gain calibration is necessary for higher accuracy
6. Available for ADP input terminal.



AC electrical characteristics

Parameter	Symbol	Min.	Typ.	Max.	Unit
SCLK clock frequency	f_{SCLK}	-	-	100	kHz
SCLK clock time "L"	t_{LOW}	4.7	-	-	us
SCLK clock time "H"	t_{HIGH}	4.0	-	-	
SDATA output delay time	t_{AA}	0.1	-	3.5	ns
SDATA output hold time	t_{DH}	100	-	-	
Start condition setup time	$t_{SU.STA}$	4.7	-	-	us
Start condition hold time	$t_{HD.STA}$	4.0	-	-	
Data input setup time	$t_{SU.DAT}$	200	-	-	ns
Data input hold time	$t_{HD.DAT}$	0	-	-	
Stop condition setup time	$t_{SU.STO}$	4.7	-	-	us
SCLK/SDATA rising time	t_R	-	-	1.0	
SCLK/SDATA falling time	t_F	-	-	0.3	
Bus release time	t_{BUF}	4.7	-	-	

MPU I/O timing diagram

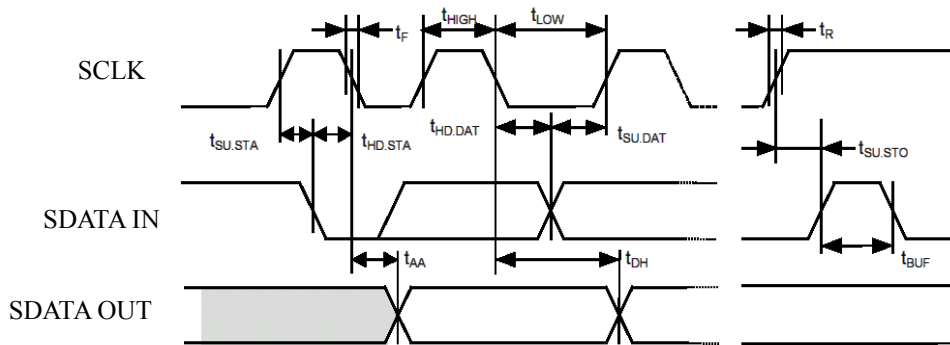



Function Description

1. MPU serial I/O function overview

1.1 Introduction

ES51996 configures a 3-wire serial I/O interface to external microprocessor unit (MPU). The SDATA pin is bi-directional and SCLK & DATA_NEW are unilateral. The SDATA pin is configured by open-drain circuit design. The DATA_NEW is used to check the data buffer of ADC ready or not. When the ADC conversion cycle is finished, the DATA_NEW pin will be pulled high until MPU send a valid read command to ES51996. After the first ID byte is confirmed, the DATA_NEW will be driven to low until the next ADC conversion finished again.

The data communication protocol is shown below. The write protocol is configured by an ID byte with four command bytes. The read protocol is configured by an ID byte with ten data bytes.

Write command:

ID byte, Write control byte1, Write control byte2, Write control byte3, Write control byte4

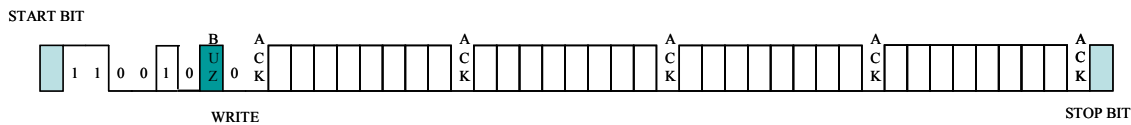

Read command:

ID byte, Read data byte1, Read data byte2 ~ Read data byte9, Read data byte10

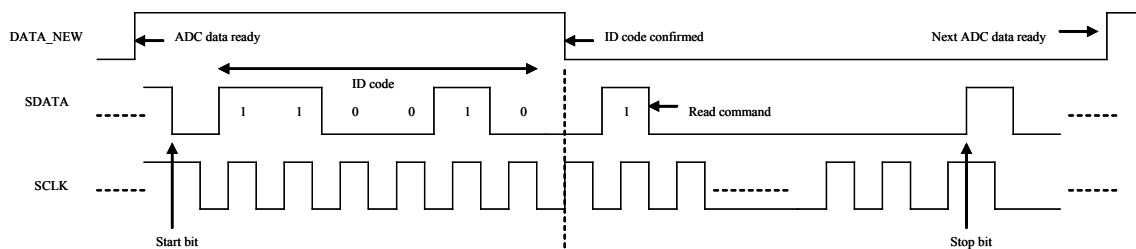
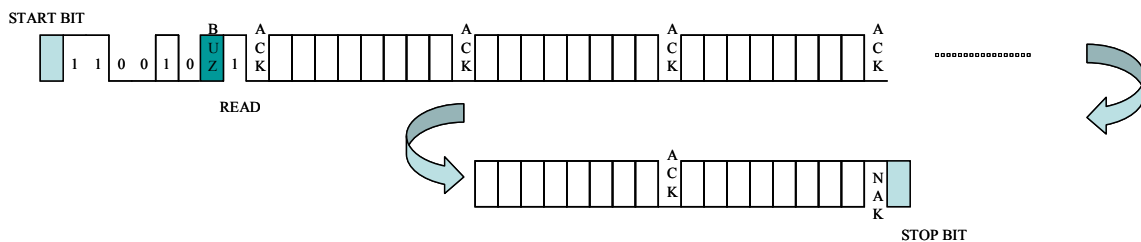



The ID byte of ES51996 is header of “110010” followed by a buzzer on/off control bit and R/W bit. The start/stop bit definition is shown on the diagram below.

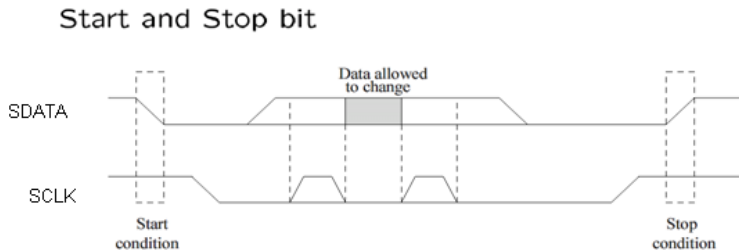

1.2 Read/Write command description

The write command includes one ID byte with four command bytes. If the valid write ID code is received by ES51996 at any time, the write command operation will be enabled.

The next table shows the content of write command.

Byte	Bit7	Bit6	Bit5	Bit4	Bit3	Bit2	Bit1	Bit0
ID	1	1	0	0	1	0	BUZ	R/W=0
W1	SHBP/DCSEL	F3	F2	F1	F0	Q2	Q1	Q0
W2	B0	B1	B2	C0	C1	FQ2	FQ1	FQ0
W3	AC	0	0	EXT	FS60/FD	LPF1	LPF0	RP
W4	PEAK	PCAL	IRQ	IRV	IRR	OP0	OP1	EXT ADP

Auxiliary low-resistance detection control bit for Continuity and Diode modes: **SHBP**

AC+DC mode selection control bit for AC+DC mode: **DCSEL**

Measurement function control bit: **F3/F2/F1/F0**

Range control bit for V/A/R/C modes: **Q2/Q1/Q0**

Range control bit for Freq mode: **FQ2/FQ1/FQ0**

Buzzer frequency selection: **B2/B1/B0**

Buzzer driver ON/OFF control bit: **BUZ**

ADC conversion rate control bit: **C1/C0**

AC mode control enable bit: **AC**

PEAK/Calibration mode enable bit: **PEAK/PCAL**

3dB BW for low-pass-filter selection: **LPF1/LPF0**

External source for Diode mode control bit: **EXT**

OP configuration control bit: **OP1/OP0**

Frequency mode input resistance control bit or output resistance control bit for AC+DC mode: **RP**

ADP mode control bit: **EXT_ADP**

ADP DC mode full scale control bit: **FS60**

Insulation mode control bit: **IRQ/IRV/IRR**

F+duty mode at 60kHz range auxiliary control bit: **FD**



The read command includes one ID byte with ten data bytes. When DATA_NEW is ready¹, MPU could send the read data command to get the result of ADC conversion (D0/D1/D2/D3)² or status flag from ES51996.

The next table shows the content of read command.

Byte	Bit7	Bit6	Bit5	Bit4	Bit3	Bit2	Bit1	Bit0
ID	1	1	0	0	1	0	BUZ	R/W=1
R1	ASIGN	BSIGN	PMAX	PMIN	BTS0	BTS1	STA0	ALARM
R2	HF	LF	LDUTY	STA1	F FIN	D0:0	D0:1	D0:2
R3	D0:3	D0:4	D0:5	D0:6	D0:7	D0:8	D0:9	D0:10
R4	D0:11	D0:12	D0:13	D0:14	D0:15	D0:16	D0:17	D0:18
R5	D1:0	D1:1	D1:2	D1:3	D1:4	D1:5	D1:6	D1:7
R6	D1:8	D1:9	D2:0	D2:1	D2:2	D2:3	D2:4	D2:5
R7	D2:6	D2:7	D2:8	D2:9	D2:10	D2:11	D2:12	D2:13
R8	D2:14	D2:15	D2:16	D2:17	D2:18	D3:0	D3:1	D3:2
R9	D3:3	D3:4	D3:5	D3:6	D3:7	D3:8	D3:9	D3:10
R10	D3:11	D3:12	D3:13	D3:14	D3:15	D3:16	D3:17	D3:18

¹Note: DATA_NEW will be active with D1 data updated when one fast ADC (FADC) conversion finished. If MCU access slow ADC output only, ten FADC conversion cycle delay is necessary. DATA_NEW for frequency or capacitance mode will be active when D0 or D3 data ready.

²Note: D0/D1/D2/D3 all are binary code format. D0 is SADC output and D1 is FADC output. The maximum data is 6300 counts for SADC and 604 counts for FADC. The maximum counts for PEAK mode is 10300, so D0 bit 13-18 could be ignored..

The ADC data output for measurement mode: **F3/F2/F1/F0**

F3	F2	F1	F0	Measurement mode	Read data bytes
0	0	0	0	V mode	D0(0:18), D1(0:9)
0	0	0	1	ACV + Hz mode	D0(0:18), D1(0:9), D3(0:18)
0	0	1	0	A mode	D0(0:18), D1(0:9)
0	0	1	1	ACA + Hz mode	D0(0:18), D1(0:9), D3(0:18)
0	1	0	0	Resistance mode	D0(0:18), D1(0:9)
0	1	0	1	Continuity mode	D0(0:18), D1(0:9)
0	1	1	0	Diode mode	D0(0:18), D1(0:9)
0	1	1	1	F + duty mode	D0(0:18), D2(0:18), D3(0:18)
1	0	0	0	Capacitance Mode	D0(0:18)
1	0	0	1	ADP mode	D0(0:18), D1(0:9)
1	0	1	0	ADP + Hz mode	D0(0:18), D1(0:9), D3(0:18)
1	1	1	1	Insulation mode	D0(0:18)



Buzzer frequency selection: **B2/B1/B0**

B2	B1	B0	Buzzer frequency
0	0	0	1.00kHz
0	0	1	1.33kHz
0	1	0	2.00kHz
0	1	1	2.22kHz
1	0	0	2.67kHz
1	0	1	3.08kHz
1	1	0	3.33kHz
1	1	1	4.00kHz

Set B2-B0 properly to get the target frequency. Use **BUZ** control bit to enable/disable the *BUZOUT* (pin82) driver output. If MPU control BUZ only, it is available to set ID byte with ending of stop bit.

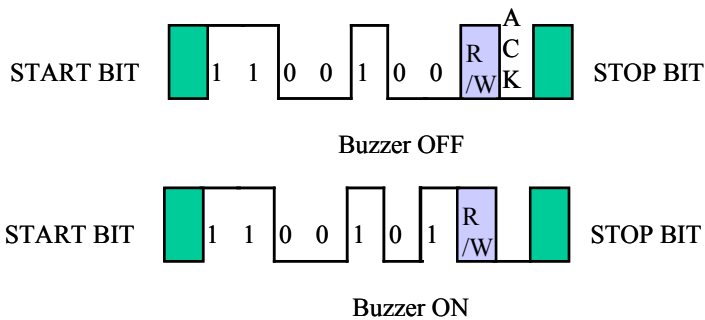

ADC conversion rate selection: **C1/C0**

C1	C0	SADC Conversion Time (High resolution ADC)	FADC Conversion Time (High speed ADC)	SADC Line noise rejection
0	0	500ms	50ms	50/60Hz
0	1	300ms	30ms	50Hz
1	0	250ms	25ms	60Hz
1	1	200ms	20ms	50Hz

Set C1-C0 to change the target conversion rate for SADC & FADC simultaneously.



Status flags for measurement mode: ● = function available

Measurement mode	ASIGN	BSIGN	PMAX	PMIN	BTS0	BTS1	ALARM
V mode	●	●	●	●	●	●	●
ACV + Hz mode			●	●	●	●	●
A mode	●	●	●	●	●	●	●
ACA + Hz mode			●	●	●	●	●
Res. mode					●	●	
Cont. mode					●	●	
Diode mode	●	●			●	●	
F + duty mode					●	●	
Cap. Mode					●	●	●
ADP mode	●	●	●	●	●	●	
ADP + Hz mode			●	●	●	●	
Insulation mode	●				●	●	
Measurement mode	HF	LF	LDUTY	STA0	STA1	F_FIN	
V mode							
V + Hz mode	●	●		●	●	●	
A mode							
A + Hz mode	●	●		●	●	●	
Res. mode							
Cont. mode							
Diode mode							
F + duty mode	●	●	●	●	●	●	
Cap. Mode				●			
ADP mode							
ADP + Hz mode	●	●		●	●	●	
Insulation mode					●		

Description of status flags:

ASIGN: Sign bit of SADC output (-1 * D0 if ASIGN=1)

BSIGN: Sign bit of FADC output (-1 * D1 if BSIGN=1)

PMAX: Indicates D0 output is the voltage of the peak maximum capacitor (pin62)

PMIN: Indicates D0 output is the voltage of the peak minimum capacitor (pin61)

BTS0/BTS1: Multi-level battery voltage indication

ALARM: Large capacitor indication/High crest factor signal detection in ACV mode

HF: Higher frequency indication for Hz mode

LF: Lower frequency indication for Hz mode

LDUTY: Low duty indication for Hz + duty mode

STA0/STA1: divider indication for Hz mode

STA0: Status flag for capacitor discharging mode

STA1: Status flag for Insulation R mode

F_FIN: Measurement cycle finished for Hz mode



1.3 Power & I/O level selection

The ES51996 provide a flexible I/O level setting for different MPU system configuration. The uP_VCC should be connected to the same potential of external Vcc of MCU. The uP_VCC is allowed to be set between DGND ~ V+. The IO_CTRL pin selects the Vss level of MCU. If IO_CTRL is set to DGND, the Vss level of MCU is the same as DGND. If IO_CTRL is set to V-, the Vss level of MCU is the same as V-.

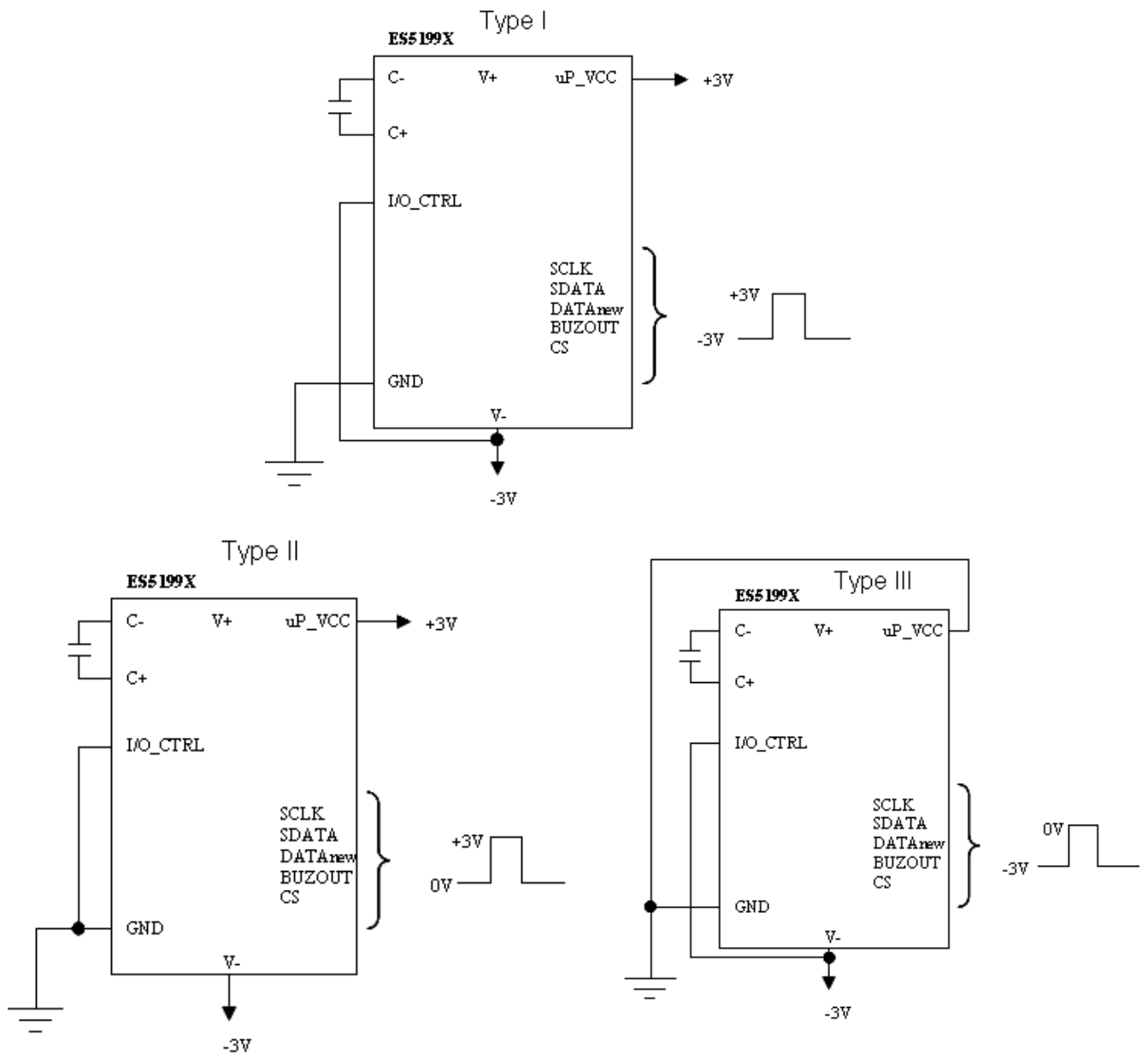

2. Operating Modes



2.1. Voltage Measurement

MPU send write command to select the voltage measurement function. The Hz mode measurement is available to be enabled with the ACV function (set AC bit to 1) simultaneously. The measured signal is applied to *VR1* terminal (pin25) through 10MΩ.

See the next table of function command:

F3	F2	F1	F0	AC	Measurement mode	Read data bytes
0	0	0	0	0	DCV mode	D0(0:18), D1(0:9)
0	0	0	0	1	ACV mode	D0(0:18), D1(0:9)
0	0	0	1	1	ACV + Hz mode	D0(0:18), D1(0:9), D3(0:18)

Note1: D0/D1/D3 all are binary format. ASIGN/BSIGN are the sign bit of D0/D1, respectively.

Note2: See PEAK mode (section 2.10) also.

Range control for voltage mode (ACV/DCV)

Q2	Q1	Q0	Full Scale Range	Divider Ratio	Resister Connection
0	0	0	600.0mV	1	VR1 (10MΩ)
0	0	1	6.000V	1/10	VR2 (1.111MΩ)
0	1	0	60.00V	1/100	VR3 (101kΩ)
0	1	1	600.0V	1/1000	VR4 (10.01kΩ)
1	0	0	1000V	1/10000	VR5 (1kΩ)

Frequency range control for ACV+Hz mode

FQ2	FQ1	FQ0	Full Scale Range
0	0	0	60.00Hz
0	0	1	600.0Hz
0	1	0	6.000kHz
0	1	1	60.00kHz

Note: See frequency mode (section 2.9) also

ALARM bit at voltage mode is used for high crest factor (HCF) signal detection. If MPU check the ALARM status flag active when data and range are stable, it should consider the making the existing range up to avoid the signal clamping saturation caused by HCF signal. There is higher peak voltage with lower RMS value for HCF signal. So if the range is up according to the ALARM bit, MCU should set the lower under-limit counts temporarily to avoid the ranging unstable for this case.



2.2 Current measurement

MPU send write command to select the current measurement function. The Hz mode measurement is available to be enabled with the ACA function (set AC bit to 1) simultaneously. The measured signal is applied to *IVSL/IVSH* terminals (pin37-38).

See the next table of function command:

F3	F2	F1	F0	AC	Measurement mode	Read data bytes
0	0	1	0	0	DCA mode	D0(0:18), D1(0:9)
0	0	1	0	1	ACA mode	D0(0:18), D1(0:9)
0	0	1	1	1	ACA + Hz mode	D0(0:18), D1(0:9), D3(0:18)

Note1: D0/D1/D3 all are binary format. ASIGN/BSIGN are the sign bit of D0/D1, respectively.

Note2: See PEAK mode (section 2.10) also.

Range control for current mode (ACA/DCA)

Q2	Q1	Q0	Full Scale Range	Input terminal
0	0	0	300mV → 6000counts	IVSL
0	0	1	300mV → 6000counts	IVSH

Current measurement mode configuration examples: (max. voltage drop 300mV)

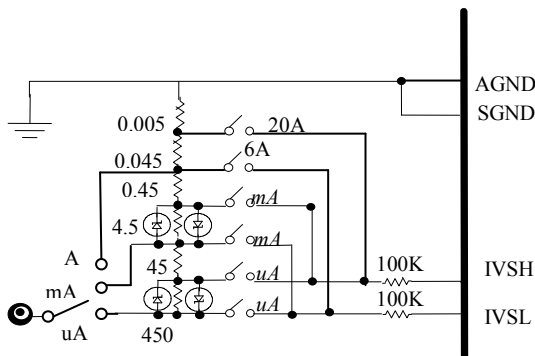
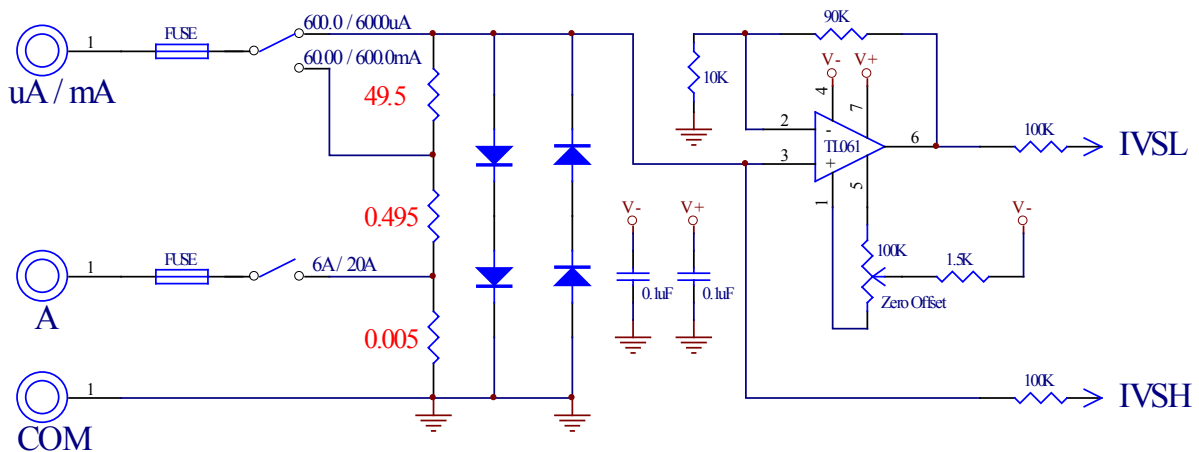

(max voltage drop = ~ 1V)



Frequency range control for ACA+Hz mode

FQ2	FQ1	FQ0	Full Scale Range
0	0	0	60.00Hz
0	0	1	600.0Hz
0	1	0	6.000kHz
0	1	1	60.00kHz

Note: See frequency mode (section 2.9) also.

2.3 Low pass filter (LPF) mode for ACA/ACV mode

A 3rd order low pass filter with is built in ES51996. The 3dB bandwidth of the low pass filter could be selectable by MPU. The LPF mode is active when the LPF control bit is set to be active. When PEAK mode is active, the LPF mode will be disabled temporarily until the PEAK mode is cancelled.

The LPF mode is allowed to be enabled in F + duty mode to reject high-frequency noise for sine wave input, but the 3dB will be fixed at 10kHz only.

LPF1	LPF0	Low pass filter effect
0	0	Disable
0	1	3dB = 1kHz
1	0	3dB = 10kHz
1	1	3dB > 100kHz

2.4 AC+DC measurement mode

Set control bit **BUF_ACDC**=1 to enter AC+DC RMS measurement mode. The additional DC low-pass filter buffer will be enabled. The DC phase output of AC+DC mode will be sent to ADC when **DCSEL**=1. The AC phase output of AC+DC mode will be sent to ADC when **DCSEL**=0. The zero offset of DC low pass filter buffer should be calibrated by setting **BUFCAL**=1. The AC+DC RMS mode is supported as follow:

F3	F2	F1	F0	AC	BUF_ACDC	Measurement mode	Read data bytes
0	0	0	0	1	1	DCV+ACV mode	D0(0:18), D1(0:9)
0	0	1	0	1	1	DCA+ACA mode	D0(0:18), D1(0:9)
1	0	0	1	1	1	ADP DC+AC mode	D0(0:18)



The auto range scheme for AC+DC RMS mode is recommended as below:

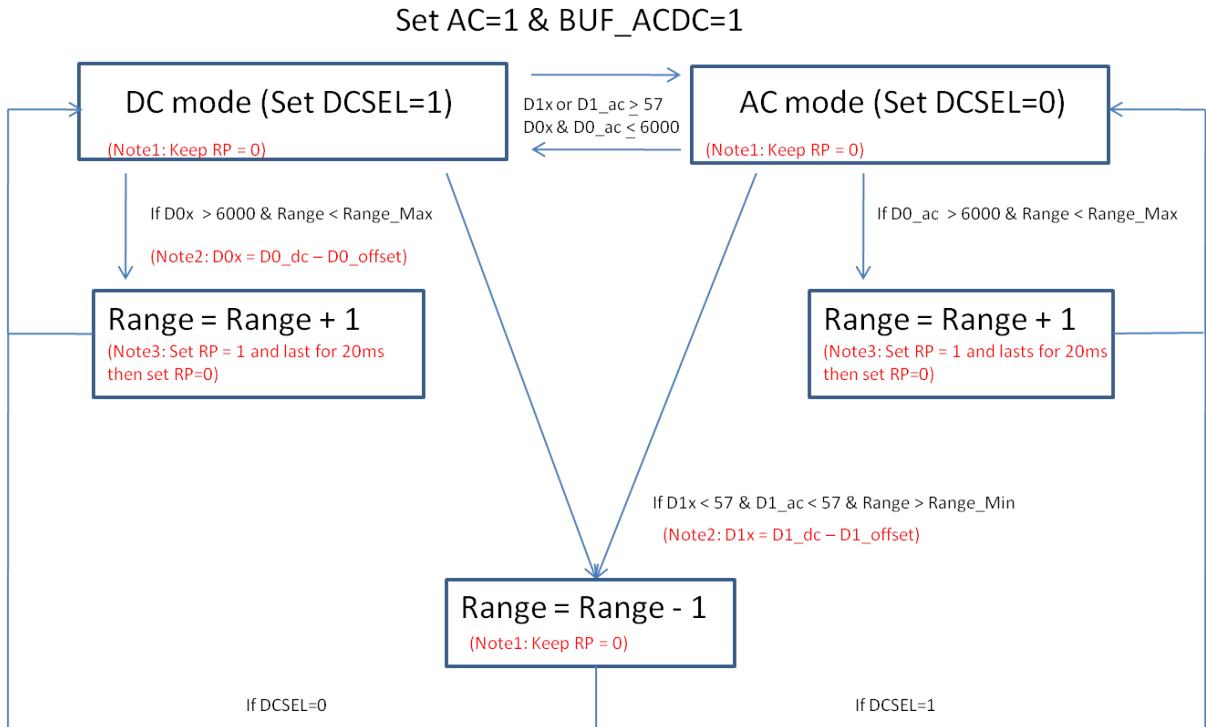

- Note1: When data is not overflow (larger than 6000 counts), always keep to set **RP=0**.
- Note2: Set **BUF_CAL = 1** to enter CAL mode to read **D0_offset** & **D1_offset**
- Note3: If Range is increasing, set **RP=1** to reduce settling time for BUFOUT (**D0_dc**) when range is modified. If **RP=1**, wait 20ms then set **RP=0** again.

The **D0_dc** & **D0_ac** is the original data from SADC of ES51996. The **D1_dc** & **D1_ac** is the original data from FADC of ES51996. **D0x** & **D1x** is real dc value deducted by dc buffer offset. The final AC+DC RMS result is square root of sum of $D0x^2$ and $D0_ac^2$.

2.5 Resistance Measurement

MPU send write command to select the resistance measurement function.

F3	F2	F1	F0	Measurement mode	Read data bytes
0	1	0	0	Resistance mode	D0(0:18), D1(0:9)

Note1: D0/D1 both are binary format. ASIGN/BSIGN bits are ignored.

Range control for resistance mode

Q2	Q1	Q0	Full Scale Range	Relative Resistor	Equivalent value
0	0	0	600.0Ω	OR1	100Ω
0	0	1	6.000KΩ	VR5	1KΩ
0	1	0	60.00KΩ	VR4 VR1	10KΩ
0	1	1	600.0KΩ	VR3 VR1	100KΩ
1	0	0	6.000MΩ	VR2 VR1	1MΩ
1	0	1	60.00MΩ	VR1	10MΩ

2.6 Capacitance Measurement

MPU send write command to select the capacitance measurement function.

F3	F2	F1	F0	Measurement mode	Read data bytes
1	0	0	0	Capacitance mode	D0(0:18)

Note1: D0 is binary format. ASIGN bit is ignored.

Range control for capacitance mode

Q2	Q1	Q0	Full Scale Range	Relative Resistor	Measurement Period
0	0	0	6.000nF	-	0.5 sec
0	0	1	60.00nF	OVX pin VR	0.5 sec
0	1	0	600.0nF	-	1.25 sec
0	1	1	6.000uF	R9K / R1K	0.4 sec max.
1	0	0	60.00uF	R9K / R1K	0.5 sec max.
1	0	1	600.0uF	R9K / R1K	1.0 sec max.
1	1	0	6.000mF	R9K / R1K	1.35 sec max.
1	1	1	60.00mF	R9K / R1K	6.75 sec max.

- ALARM bit at capacitance mode is used for increasing the ranging speed. If MPU check the ALARM=1 at lower range, it could set the next range to 6.000uF directly and the ADC output should be ignored.
- STA0 status bit is used for detection of DUT capacitor voltage. If STA0=1, the internal capacitor discharging mode is active and the capacitance measurement is inhibited. It is recommended to discharge the DUT capacitor externally.



2.7 Continuity Check measurement

MPU send write command to select the continuity measurement function.

F3	F2	F1	F0	Measurement mode	Read data bytes
0	1	0	1	Continuity mode	D0(0:18), D1(0:9)

Note1: D0/D1 both are binary format. ASIGN/BSIGN bits both are ignored.

Continuity mode shares the same configuration with 600.0Ω resistance measurement circuit and support the low-resistance detection. If the *STBEEP* output (pin64) is low, it means the low-resistance status is detected (It means the *OVX* terminal voltage less than -7mV). It could be faster than the FADC result, so MPU could monitor the *STBEEP* output and FADC (D1) data output make the high speed detection for short circuit detection. Set **SHBP**=1 to enable the built-in buzzer driving automatically when *STBEEP* is active.

2.8 Diode Measurement

MPU send write command to select the diode measurement function.

F3	F2	F1	F0	Measurement mode	Read data bytes
0	1	1	0	Diode mode	D0(0:18), D1(0:9)

Note1: D0/D1 both are binary format. ASIGN/BSIGN are the sign bit of D0/D1, respectively.

Diode measurement mode shares the same configuration with 6.000V voltage measurement circuit and support the low-resistance detection. If the *STBEEP* output (pin64) is low, it means the low-resistance status is detected (It means the *OVX* terminal voltage less than 9mV). It could be faster than the FADC result, so MPU could monitor the *STBEEP* output and FADC (D1) data output make the high speed detection for short circuit detection. Set **SHBP**=1 to enable the built-in buzzer driving automatically when *STBEEP* is active.

The default source voltage at diode mode is the same as V+ potential. MPU could set the control bit **EXT**=1 to change the source voltage to external source. The external voltage source (positive or negative) input applied from *EXTSRC* (pin16). The available external source range should be from V+ to V-.



DIODE mode configuration

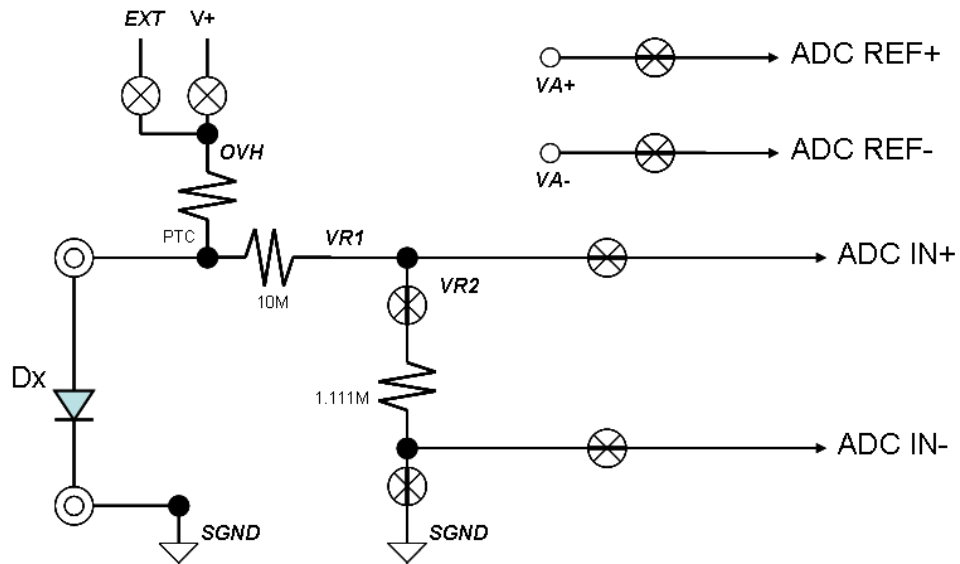

2.9 Frequency/duty cycle mode measurement

The default typical input impedance of frequency with duty cycle mode is 1MΩ. The MPU could set control bit **RP=1** to change the input impedance down to 100kΩ. MPU send write command to select the frequency/duty cycle measurement function.

F3	F2	F1	F0	Measurement mode	Read data bytes
0	1	1	1	Hz + Duty mode	D0(0:18), D2(0:18), D3(0:18)

Note1: D0/D2/D3 all are binary format. ASIGN bit is ignored.

Note2: Set LPF1 = 1 to enable the smooth function for sine wave input automatically

Range control for frequency mode

FQ2	FQ1	FQ0	Full Scale	Conversion period
0	0	0	60.00Hz	700ms (fixed)
0	0	1	600.0Hz	700ms (fixed)
0	1	0	6.000KHz	700ms (fixed)
0	1	1	60.00KHz	700ms (fixed)
1	0	0	600.0KHz	See next table
1	0	1	6.000MHz	
1	1	0	60.00MHz	

Available minimum frequency input (Depends on ADC conversion rate setting)

C1	C0	F _{MIN} (AC+Hz mode)	F _{MIN} (Hz+Duty mode)	Hz+Duty Conv. Period
0	0	4.00Hz	4.00Hz	700ms
0	1	6.00Hz		420ms
1	0	8.00Hz		350ms
1	1	10.00Hz		280ms

Frequency & duty cycle mode computed by D0/D2/D3 (if F_FIN=1)

Flag	STA0=1	STA0=0	
		STA1=1	STA1=0
60.00Hz	FREQ=100000000/D3	FREQ=400000000/D3	FREQ=800000000/D3
600.0Hz	FREQ=10000000/D3	FREQ=40000000/D3	FREQ=16000000/D3
6.000KHz	FREQ=2000000/D3	FREQ=32000000/D3	FREQ=25600000/D3
¹ 60.00KHz	FREQ=200000/D3	FREQ=2560000/D3	FREQ=204800000/D3
600.0KHz	FREQ = D0		
6.000MHz			
60.00MHz			

¹Note: Set FD=1 to change the frequency calculation at 60kHz range to FREQ=D0.

Status Flag	LDUTY=1	LDUTY=0
Duty cycle (<60kHz)	10000-D2*10000/D3	D2*10000/D3



The status flag F_FIN indicate the frequency input signal available ($> F_{MIN}$) or not. If the computed result less than F_{MIN} , the frequency/duty cycle readings should be set to zero.

The status flags HF & LF are used for fast judgment of proper range. If frequency input is larger than 7 kHz, HF will be active. If frequency input is floating or frequency detected too low, LF will be active.

Auto range consideration for MPU by using Status Flags of frequency mode

Flag Range	F_FIN=0	F_FIN=1	F_FIN=1	
	LF=0	LF=1*	HF=LF=0	HF=1**
60.00Hz 600.0Hz 6.000KHz	Data and Range is not necessary to be updated	Hz/Duty=0	Change range depends on data computed	Set range to 60.00kHz range
60.00KHz 600.0KHz 6.000MHz 60.00MHz		Set range to 60.00Hz range		Change range depends on data computed

*Note: LF=1 @ 60Hz range implies the frequency is not available to be measured. The Hz/Duty readings should be set to zero.

**Note: When ACV+Hz/ACA+Hz/ADP+Hz mode is selected, the HF status should be ignored. Change range depends on data calculation result.

Duty cycle mode range (Input sensitivity $> 2V_{pp}$ @ duty cycle = 5.0% & 95.0%)

Freq. range	Duty range
60.00Hz 600.0Hz	5.0% - 95.0%
6.000KHz	10.0% - 90.0%
*60.00KHz	20.0% - 80.0%

*Note; Set FD=1 to improve the duty cycle resolution at 60kHz range.



2.10 ADP mode

MPU send write command to select the ADP mode measurement function. The Hz mode measurement is available to be enabled with the ADP AC function (set AC bit to 1) simultaneously. The measured signal is applied to *ADP* terminal (pin39). The signal full scale is 600mV for DC mode and 600mVrms for AC mode. The **FS60** control bit is used for ADP DC mode. When **FS60**=1, the full scale will be change from 600mV to 60mV. It means the resolution will be improved to 0.01mV, but the ADC conversion rate will be reduced to 0.9 /sec.

See the next table of function command:

F3	F2	F1	F0	AC	Measurement mode	Read data bytes
1	0	0	1	0	ADP DC mode	D0(0:18), D1(0:9)
1	0	0	1	1	ADP AC mode	D0(0:18), D1(0:9)
1	0	1	0	1	ADP + Hz mode	D0(0:18), D1(0:9), D3(0:18)

Note1: D0/D1/D3 all are binary format. ASIGN/BSIGN are the sign bit of D0/D1, respectively.

Note2: See PEAK mode (section 2.10) also.

Frequency range control for ADP+Hz mode

FQ2	FQ1	FQ0	Full Scale Range
0	0	0	60.00Hz
0	0	1	600.0Hz
0	1	0	6.000kHz
0	1	1	60.00kHz

Note: See frequency mode (section 2.9) also

If MPU set the control bit **EXT_ADP**=1, the voltage on *EXTSRC* pin could be switched to *ADP* terminal internally. It is helpful for a voltage pulled application of ADP mode.

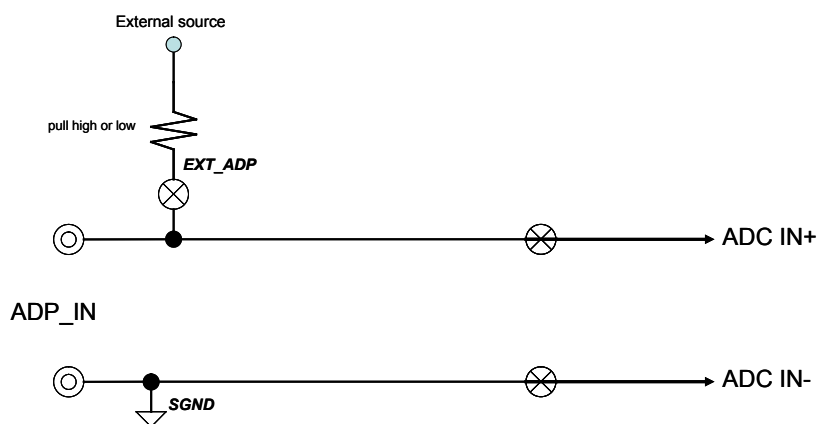



2.11 Peak-hold measurement mode

ES51996 provides a peak hold function to capture the real peak value for voltage or current measurement mode. In a case of a 1V sine wave input voltage, the peak hold function gets a maximum peak value of 1.414V and minimum peak value of -1.414V ideally. Set the control bit **PEAK=1** to force the ES51996 entering PEAK measurement mode. Peak Hold function is divided into two parts of peak maximum and peak minimum conversion. High resolution SADC performs peak maximum and peak minimum conversion in turn, not at the same time. The status flag P_{MAX} or P_{MIN} shows which type the peak value is. If P_{MAX}=1(P_{MIN}=1), the SADC output D0 is the conversion data on P_{MAX} (P_{MIN}) terminals (pin 61/62). The MPU should make the comparison procedure to get the maximum value of P_{MAX} data and minimum value of P_{MIN} data. The max counts for D0 is 10300.

Peak calibration mode

At PEAK-Hold measurement mode, the offset voltage of internal operation amplifier will cause an error. To obtain a more accurate value, the offset error must be canceled. ES51996 provides the peak calibration feature to remove the influence on accuracy by internal offset voltage. Set the control bit **PCAL=1** to enter peak calibration mode. When PCAL mode is active, the SADC of ES51996 will output the calibration value of peak maximum and minimum conversion in turn. The offset values should be memorized respectively and deducted from the data of P_{MAX}/P_{MIN} at the normal peak measurement mode.

Set PCAL=1 or PEAK=1		
Status indication	P _{MAX} =1, P _{MIN} =0	P _{MAX} =0, P _{MIN} =1
ADC data	V _{P_{MAX}.C}	V _{P_{MIN}.C}

V_{P_{MAX}.C} and V_{P_{MIN}.C} are not the real-time value of peak-hold voltage. They are the voltage stored on terminal capacitor (pin61-62). Because the capacitor will be self-discharging, so MCU need to compare the V_{P_{MAX}.C} & V_{P_{MIN}.C} respectively and memorize the maximum and minimum peak values in turn.

2.12 Insulation resistance measurement mode

The ES51996 is built-in analog switches network to support the insulation resistance measurement mode. By implementation of external high voltage source, the insulation resistance could be obtained from SADC output of ES51996 and calculated by microprocessor easily. The insulation mode is separated into two modes which are insulation V mode and insulation R mode which are described below.

Insulation V mode configuration

F3	F2	F1	F0	IRV	AC	Measurement mode	Read data bytes
1	1	1	1	1	0/1	Insulation (DC/AC) V mode	D0(0:18)

Note1: D0 is binary format. ASIGN is the sign bit D0.

Insulation V mode

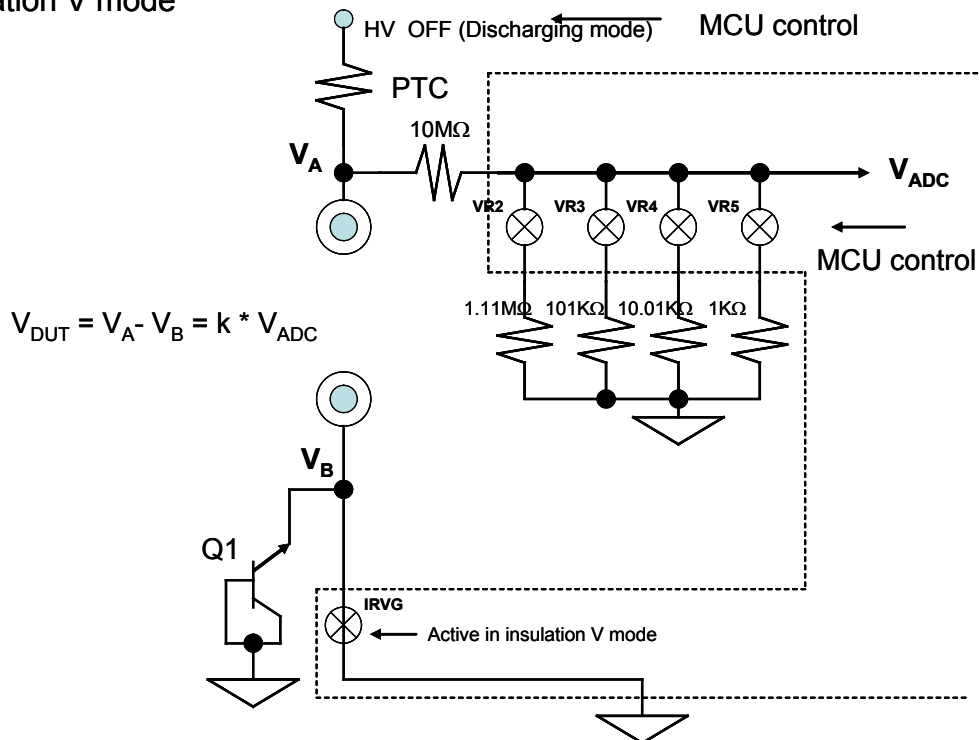

Note: The on-resistance of internal analog switches could be omitted.

Before measure insulation resistance, it is necessary to measure V_{DUT} . If V_{DUT} is too high, the resistance measurement should be forbidden. The insulation V mode is implemented by the same configuration with Voltage mode. The k factor of diagram is depended on the voltage range. During insulation V mode, an external fast discharging path should be applied on the HV sourcing part to release the high voltage charge on the DUT if it is capacitive load.

Range control for insulation V mode

Q2	Q1	Q0	Full Scale Range
0	1	0	60.00V
0	1	1	600.0V
1	0	0	1000V

Note: 600mV – 6V ranges are omitted.

Insulation R mode configuration

F3	F2	F1	F0	IRV	IRR	Measurement mode	Read data bytes
1	1	1	1	0	1	Insulation R mode	D0(0:18)

Insulation R mode

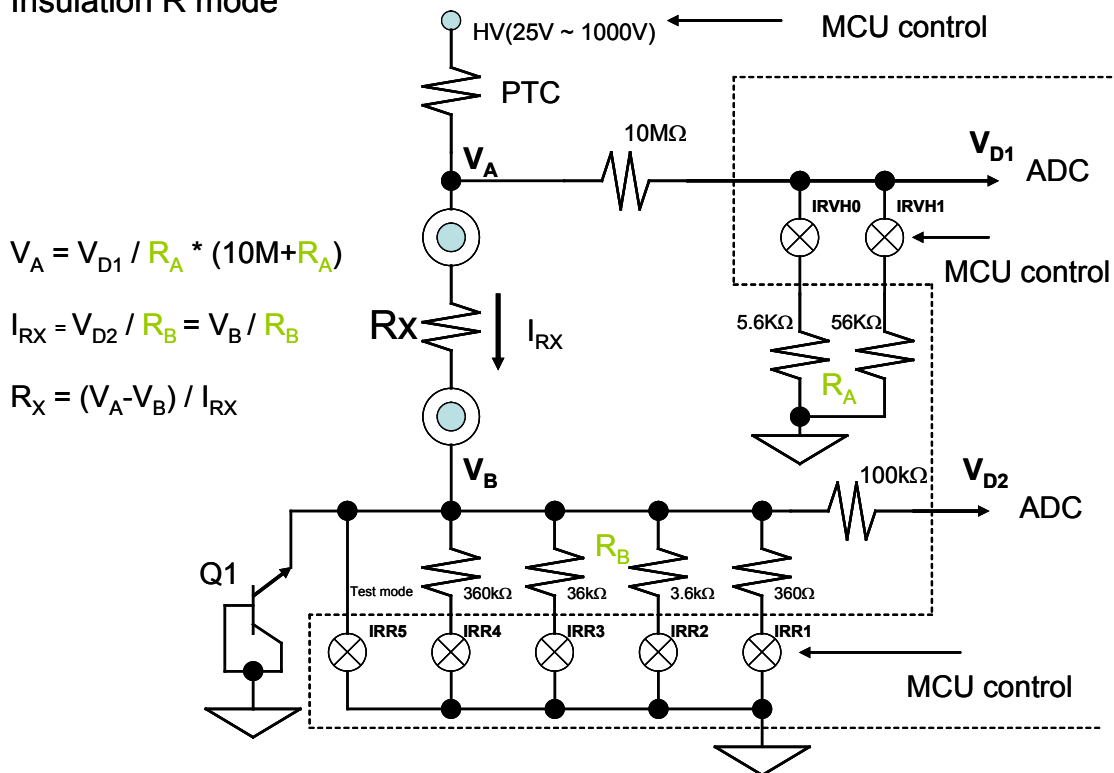

Note: ADC full scale is 600mV typically.



During insulation R mode is setting, the SADC of ES51996 will convert the DUT terminal voltage V_A (higher voltage side V_{D1}) & V_B (lower voltage side V_{D2}) sequentially. Use ohm's law calculation $\{R_x = (V_A - V_B) / I_{RX}\}$ to get the target DUT insulation resistance easily. The microprocessor gets the ADC data by checking status bit **STA1**:

Status indication	STA1=1	STA1=0
ADC data	V_{D1}	V_{D2}

The proper range control (R_A / R_B selection) depends on the HV source. The R_A selection is controlled by **IRQ** control bit. The R_B is selected by **Q2/Q1/Q0** control bits. The next range table is an example of HV sourcing from 25V to 1000V.

$R_B \backslash R_A$	Set IRQ=1 (IRVH1)			Set IRQ=0 (IRVH0)		
	HV=25V	HV=50V	HV=100V	HV=250V	HV=500V	HV=1000V
<i>IRR1</i>	15k Ω ~ 150k Ω	30k Ω ~ 300k Ω	60k Ω ~ 600k Ω	0.15M Ω ~ 1.50M Ω	0.30M Ω ~ 3.00M Ω	0.60M Ω ~ 6.00M Ω
<i>IRR2</i>	0.15M Ω ~ 1.50M Ω	0.30M Ω ~ 3.00M Ω	0.60M Ω ~ 6.00M Ω	1.5M Ω ~ 15.0M Ω	3.0M Ω ~ 30.0M Ω	6.0M Ω ~ 60.0M Ω
<i>IRR3</i>	1.5M Ω ~ 15.0M Ω	3.0M Ω ~ 30.0M Ω	6.0M Ω ~ 60.0M Ω	15M Ω ~ 150M Ω	30M Ω ~ 300M Ω	60M Ω ~ 600M Ω
<i>IRR4</i>	15M Ω ~ 150M Ω	30M Ω ~ 300M Ω	60M Ω ~ 600M Ω	0.15G Ω ~ 1.50G Ω	0.30G Ω ~ 3.00G Ω	0.60G Ω ~ 6.00G Ω

Q2	Q1	Q0	R_B range	Best resolution*
0	0	1	<i>IRR1</i>	1k Ω
0	1	0	<i>IRR2</i>	0.01M Ω
0	1	1	<i>IRR3</i>	0.1M Ω
1	0	0	<i>IRR4</i>	1M Ω
1	0	1	<i>Test mode (IRR5)</i>	N/A

*Note: The best resolution depends on the external high voltage and SADC readings.

2.13 Sleep

Set **CS** pin (pin 80) to logic low to make the ES51996 entering the sleep mode. The current consumption will be less than 3uA typically. Set **CS** pin to logic high or kept floating, the ES51996 will return to normal operation.



2.14 Multi-level battery voltage indication

The ES51996 is built-in a comparator for batter voltage indication. The voltage is applied to *LBAT* pin (pin 89) vs. *V-* terminal. MPU could check the status bit *BTS1/BTS0* and monitor the *LBAT* voltage status.

Battery voltage	BTS1	BST0
$V_{LBT} > V_{t1}$	1	1
$V_{t2} < V_{LBT} < V_{t1}$	1	0
$V_{t3} < V_{LBT} < V_{t2}$	0	1
$V_{LBT} < V_{t3}$	0	0

Low battery configuration for 9V/1.5V*4/1.5V*3 battery

Low battery test circuit (a)

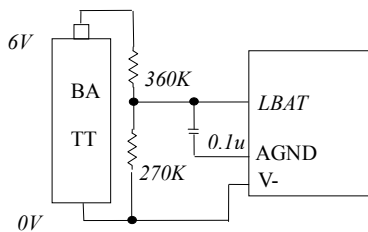

Low battery test circuit (b)

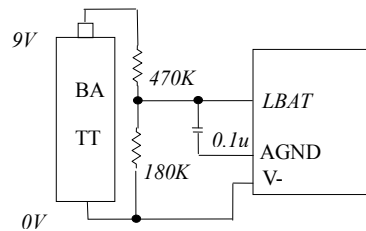

Low battery test circuit (c)

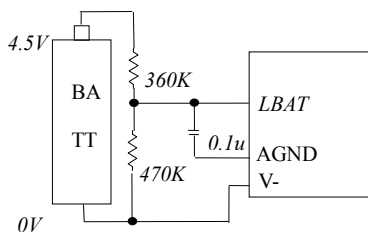



2.15 Independent OPAMP

ES51996 is built-in an independent OPAMP with low drift offset using for general purpose.

MPU could control the OP1/OP0 to change the OPAMP configuration:

OP1	OP0	OPAMP configuration
0	0	Normal
0	1	OP disable
1	0	Unity gain buffer
1	1	Zero calibration

Independent OPAMP configuration

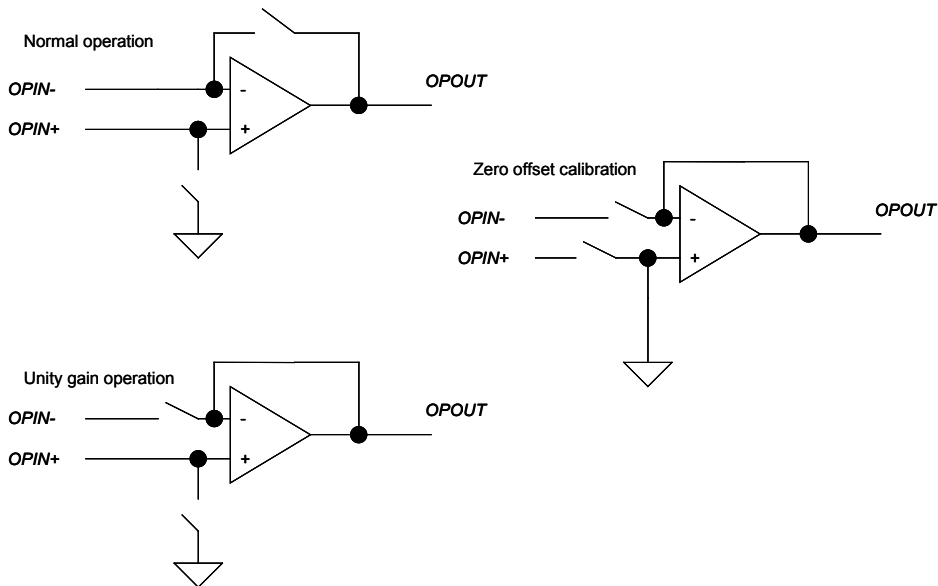



3. Application Circuit

3.1 AVG circuit

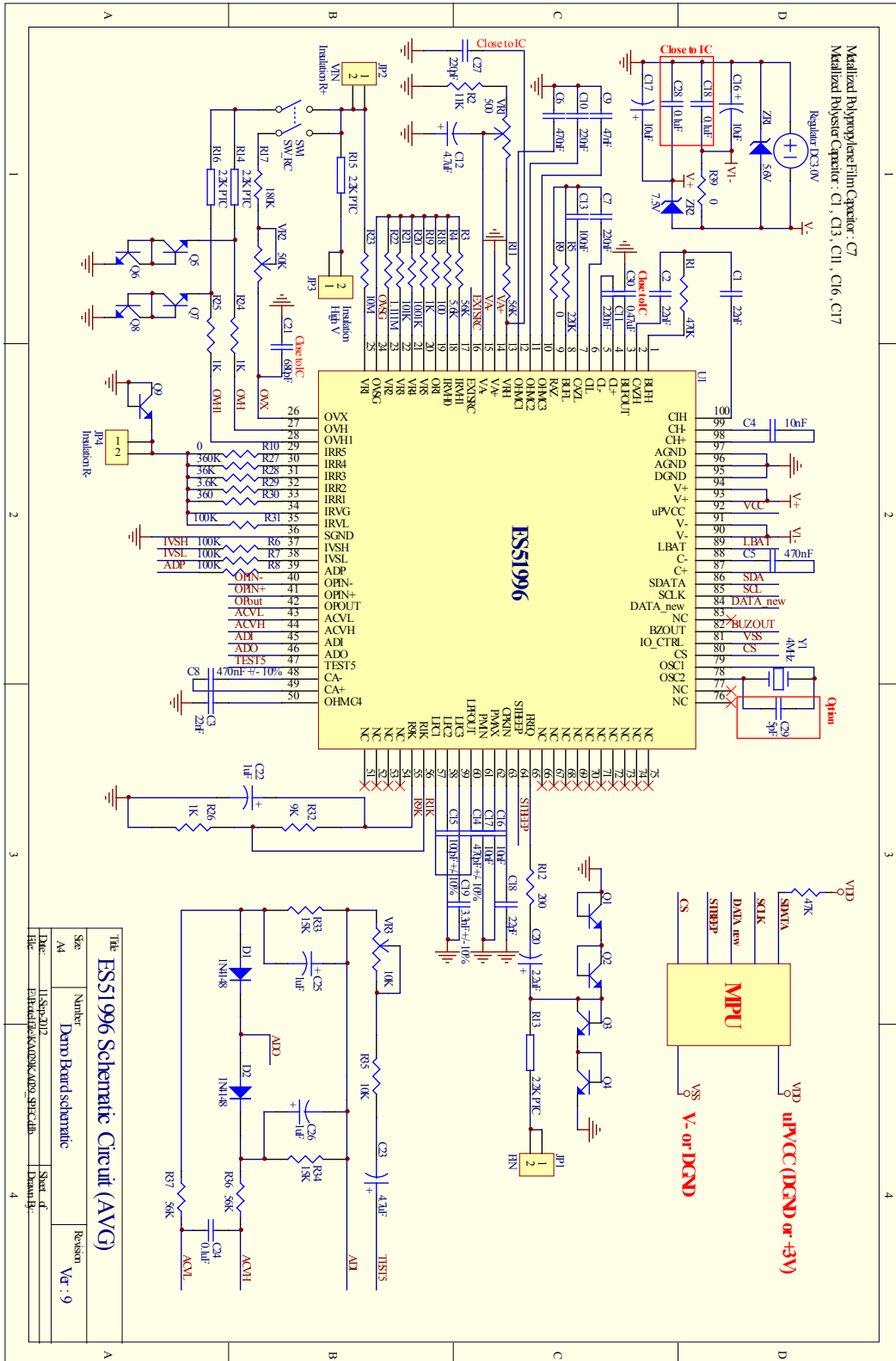



3.2 RMS circuit (ES636)

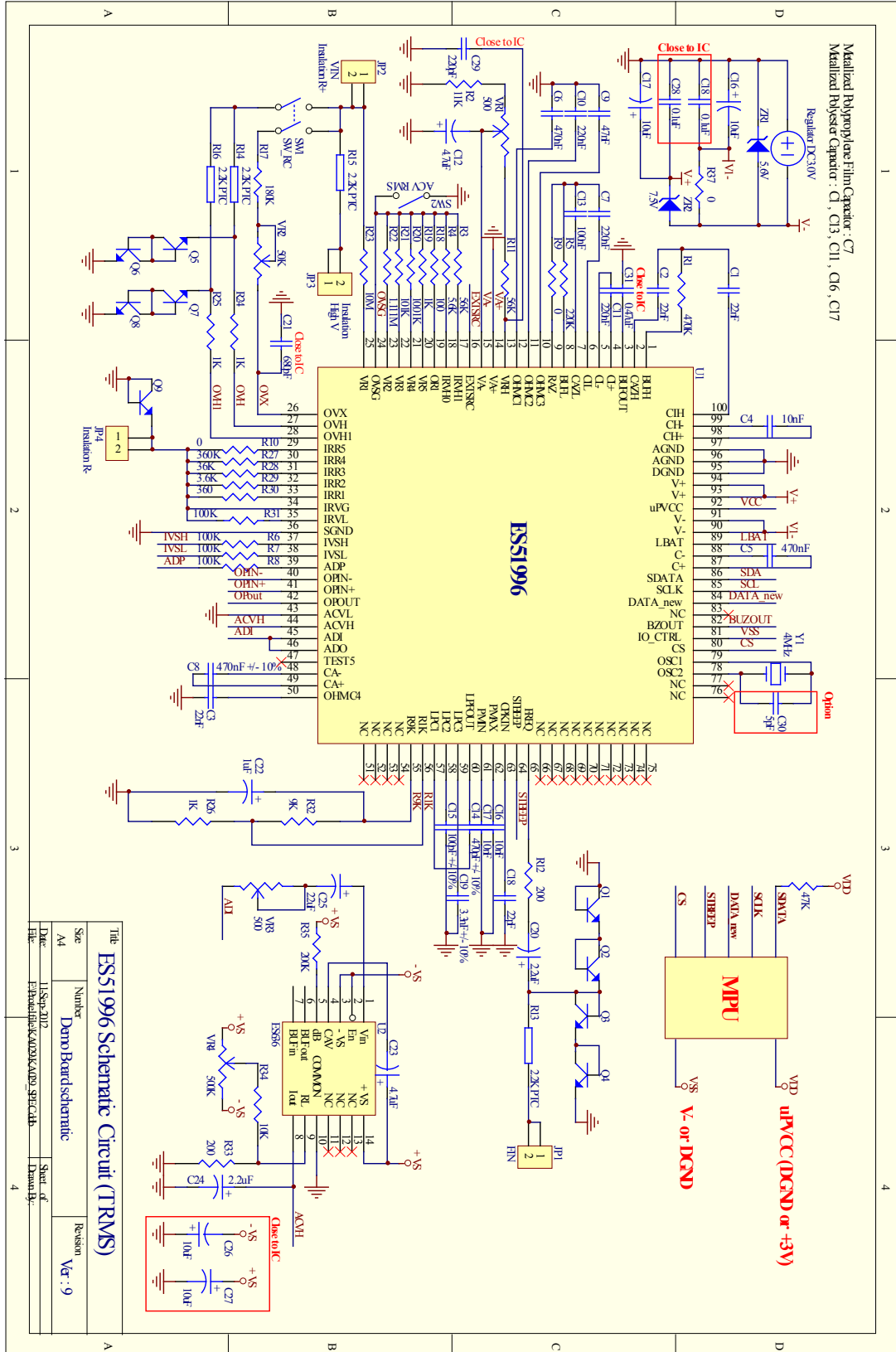



4. Package Information

4.1 100L LQFP Outline drawing

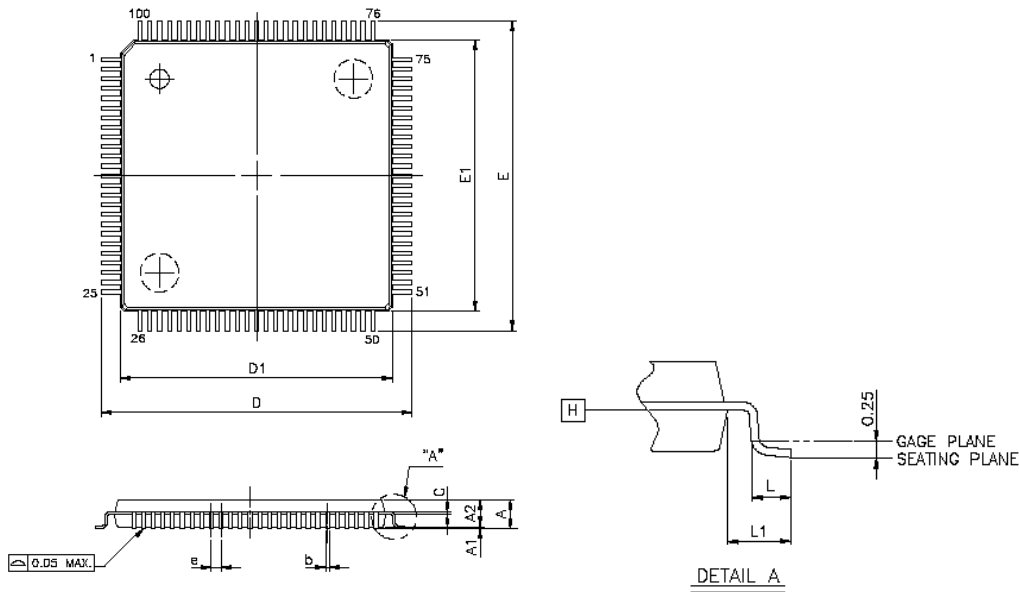

4.2 Dimension parameters

VARIATIONS (ALL DIMENSIONS SHOWN IN MM)

SYMBOLS	MIN.	NOM.	MAX.
A	--	--	1.60
A1	0.05	--	0.15
A2	1.35	1.40	1.45
b	0.17	0.20	0.27
c	0.09	0.127	0.20
D	16.00 BSC		
D1	14.00 BSC		
E	16.00 BSC		
E1	14.00 BSC		
e	0.50 BSC		
L	0.45	0.60	0.75
L1	1.00 REF		